



**waste
management**



two wheeled bins



It 120

It 120 Wheeled Bin in HDPE according to UNI EN 840 (UNI 10571 and DIN 30740 standard)

Body and lid of the container are of single piece design injection moulded in virgin High Density Polyethylene (HDPE) material.

Manufactured using completely recyclable high quality materials, UV stabilised, resistant to decay, frost, heat, water and most chemicals.

The container is of a smooth, no sharp edge and ergonomic wall design.

Fitted with 200 mm diameter rotating swivel wheels.

Colour choices are free from heavy metals (cadmium and lead) and toxic substances in line with current legislation.

The two rear wheels may easily be replaced and are fixed to a high quality steel zinc plated axle capable of withstanding high impact.

Moulded rear handles allow ease and stability of movement.

The lid is hinged and incorporates two front handles for ease of opening.

When closed the lid and lip seal prevent rain water from entering the container.

All containers are compatible with identification/weighing systems and have an RFID chip nest aperture under the front lip.

Containers can be personalised with logo's, stickers, embossed marking and serial numbering.

All Jcoplastic containers are certified to EN 840 and are GS quality certified by the independent authority LGA-GS of Nuremberg (Germany).

Standard colour green. Other colours on request.

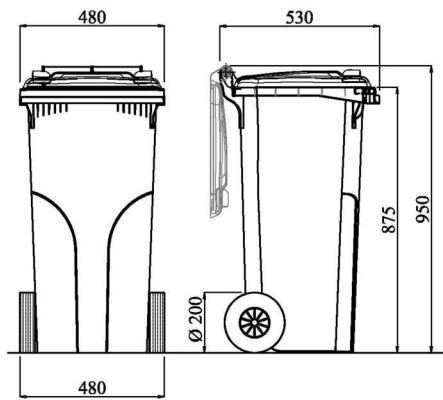

Technical specifications

nominal volume	120	lt
tipping edge	875	mm
loading capacity	48	kg
length	530	mm
width	480	mm
height	950	mm
wheelbase	480	mm
weight	7,5	kg
wheel diameter	200	mm

Customizations on request

- Foot pedal for lid operation
- Jco gravity lock with or without triangular universal key
- Jco lock with triangular key (no gravity)
- Sudhaus gravity lock

- Reflective according to class 1 or class 2
- Embossing and hot foil stamps
- Serial numbers and customized labels
- Chip installation



reflective version



lid for glass/tins - 160 mm



foot pedal version



noise reduction application



noise reduction application



jco lock triangular key

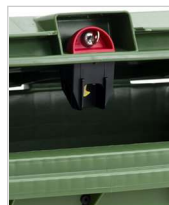

sudhaus gravity lock



central gravity lock



chip nest aperture



reinforced comb with spring system



foot pedal



reflective



generic stickers



In-Mould labeling



embossing



hot foil stamping



serial numbers customized labels



green



blue



dark gray



light gray



brown



yellow



white



CE PRINTING and indication of sound power level according to 2000/14/EC directive on 80L, 120L, 140L, 240L, 360L, 660L, 770L, 1000L, 1100L flat lid and round lid



The products 240L, 360L, 660L, 770L, 1000L, 1100L are ONU ADR certified for the transport of clinical waste. The box 600L FOR SPECIAL USES IS ADR ONU certified for the transport of expired batteries



The Jcoplastic products are injection moulded in high density polyethylene (HDPE) and they are 100% recyclable



The Jcoplastic products from 80L to 2400L are certified GS/LGA (certificate of the product and the safety at work according to EN 840 standard)



Jcoplastic SpA
viale Spagna 71, Z.I.
84091 Battipaglia (SA) • Italy
ph +39 0828 392111 • fax +39 0828 392164
export@jcoplastic.com • www.jcoplastic.com

For further information please visit
www.jcoplastic.com

Jcoplastic reserves the rights to alter all information included in this sheet at any time without given notice.

