



waste
management



compact range



It 660

It 660 Wheeled Bin in HDPE according to UNI EN 840 (UNI 10571 and DIN 30700 standard)

Body and lids are of one piece single moulded design made of High Density Polyethylene (HDPE). The material used is of a high quality, UV stabilized, resistant to decay, frost, heat, water and most chemicals. Minimal handling, low price of exercise, reduction of noise pollution, 100% recyclable and completely washable thanks to round shape of the container (without corners) and absence of recess. Dirt won't stick to the surfaces exposed to the flow of equipment washing ends. Four solid rubber wheels (200 mm diameter) easily to replace and handle. Foot brakes on two front wheels. All wheels full 360° swivelling. Provided with a drainage plug made of HDPE to discharge the water used for washing and cleaning. Directional blocks on two wheels available on request as optional.

The noise during emptying has been reduced and kept down within the limits thanks to the special form of the container and its project solutions. Along the upper edge of the container a reversed profile "U" has been carried out with internal ribs for giving more perimeter structural sturdiness without need of metal reinforcements or any other bearing structure.

The edge presents a shape in the form of a step provided with six reinforcement ribs appropriate to the lifting/ tilting of the container when empty by the front "comb". The lid is hinged with two handles for ease of opening. When closed the lid and lip seal prevent rainwater from entering the container. The lid is articulated by two pivots made of HDPE placed on the hinges and put on the upper ends of the lids. GS mark (issued by LGA Nuremberg, Germany) showing safety and EN compliance testing.

Standard colours: green, grey, blue, brown. Other colours by request. Colouring is obtained directly by the raw material during the moulding. Dyes used to guarantee the longevity of colour are stabilized against atmospheric agents and U.V. rays. Moreover, according to the environmental policy of Jcoplastic S.p.A., they are free from heavy metals (cadmium, lead, etc.) and any other toxic substances which can be dangerous for our environment.

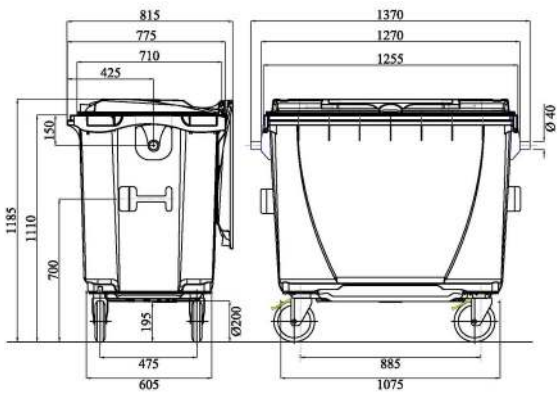

Technical specifications

nominal volume	660	lt
length	1370	mm
width	775	mm
height	1185	mm
tipping edge	1110	mm
track	475	mm
wheelbase	885	mm
weight	35	kg
loading capacity	264	kg

Customizations on request

- Selective collection versions
- Foot pedal for lid opening
- Jco gravity lock with or without triangular universal key
- Jco lock with triangular key (no gravity)

- Reflective according to class 1 or class 2
- Embossing and hot foil stamps
- Serial numbers and customized labels
- Chip installation



reflective version



lid for multimaterial/paper



lid for glass/tins (detail)



foot pedal for lid opening



tow hook



foot pedal provided with shock-absorber



empty by upturning using forks



reinforced fastening wheel



reinforced comb with spring system

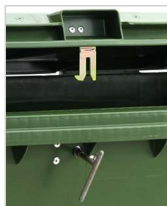

jco lock triangular key



sudhaus gravity lock



central gravity lock



embossing



hot foil stamping



serials / stickers customized labels



green



blue



dark gray



light gray



brown



yellow



white



CE PRINTING and indication of sound power level according to 2000/14/EC directive on 80L, 120L, 140L, 240L, 360L, 660L, 770L, 1000L, 1100L flat lid and round lid



The products 240L, 360L, 660L, 770L, 1000L, 1100L are ONU ADR certified for the transport of clinical waste. The box 600L FOR SPECIAL USES IS ADR ONU certified for the transport of expired batteries



The Jcoplastic products are injection moulded in high density polyethylene (HDPE) and they are 100% recyclable



The Jcoplastic products from 80L to 2400L are certified GS/LGA (certificate of the product and the safety at work according to EN 840 standard)



Jcoplastic SpA
viale Spagna 71, Z.I.
84091 Battipaglia (SA) • Italy
ph +39 0828 392111 • fax +39 0828 392164
export@jcoplastic.com • www.jcoplastic.com

For further information please visit
www.jcoplastic.com

Jcoplastic reserves the rights to alter all information included in this sheet at any time without given notice.

